

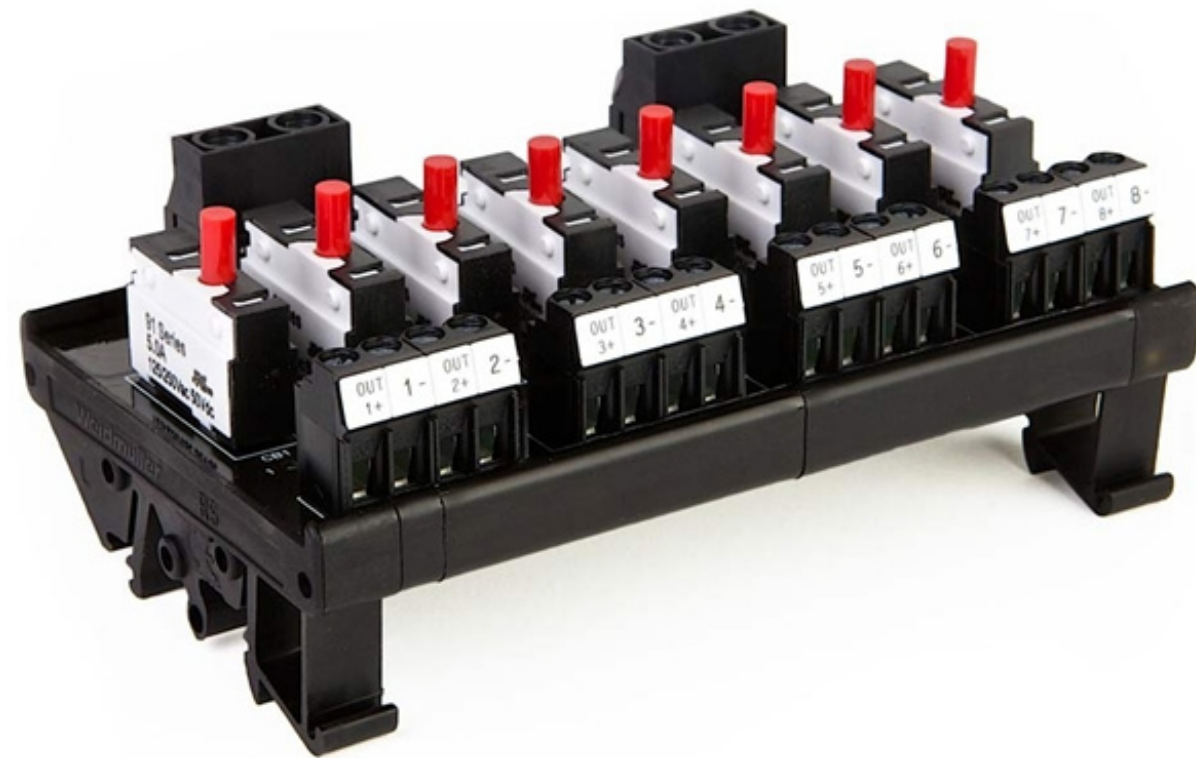

Determining if SIGNEXT® CBM Modules Are Suitable For Your Application



AC CIRCUITS

Suitability of any protective devices such as a fuse or circuit breaker is determined by the available fault current from the power source and the interrupting rating of the protective device.

If the power source can deliver fault currents of several thousand amps then a circuit breaker that can interrupt a maximum of 1000A is clearly not suitable. In many control cabinets the actual control components, e.g. PLC, interface modules, signal conditioners, etc., are powered by a control transformer. The transformer takes the incoming power and drops it down to 120V. Any protective devices in the control circuitry must be able to interrupt the maximum fault current the control transformer can deliver.

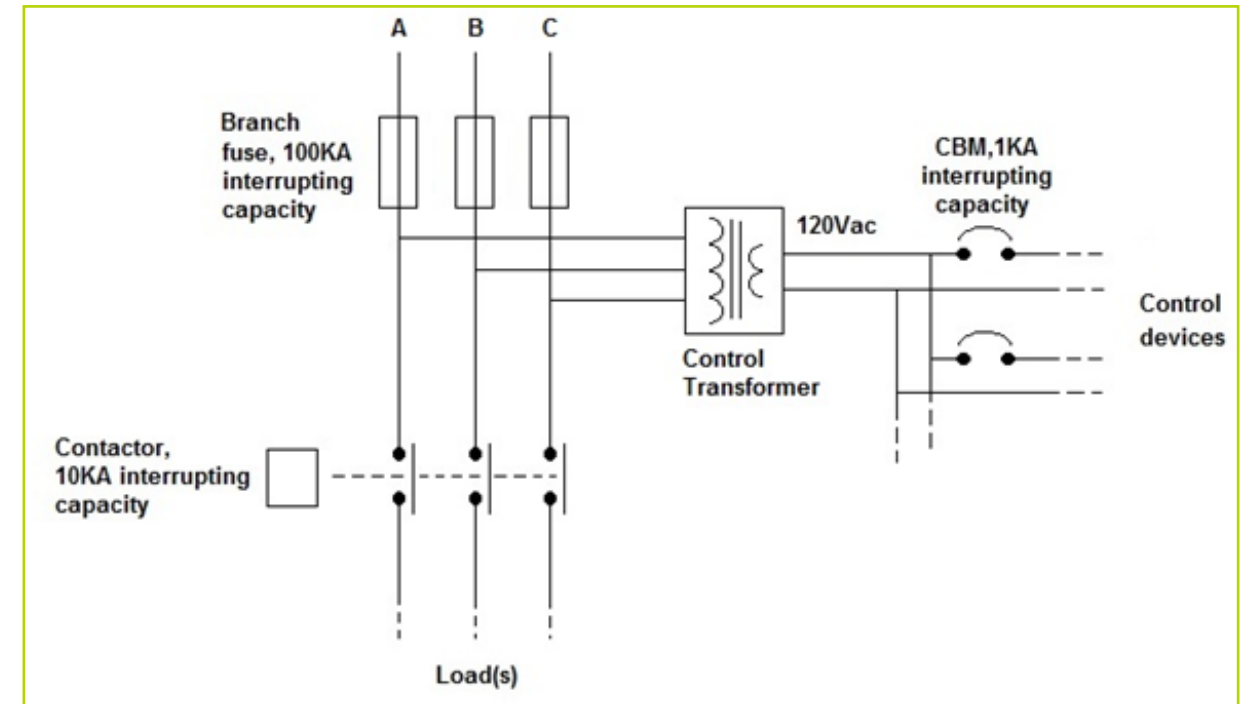

To determine if the CBM circuit breaker is suitable in the application shown above it is necessary to calculate the available fault current available from the control transformer. For this the transformer impedance must be known.

Transformer impedance is specified as a percentage and is the percentage of the rated input voltage required to produce the rated full load secondary current. The secondary of the transformer is short circuited and the primary voltage is increased from 0V until the rated full load current flows in the secondary.

A quick method to determine the available fault current, or short circuit current, is to calculate the available fault power. If a 1KVA control transformer has an impedance of 1.5% then the available fault current is approximately:

$$\begin{aligned} PSC &= KVA / \%Z \\ &= 1 / 0.015 \\ &= 66.7KVA \end{aligned}$$

Assuming the control transformer is designed to deliver 120V at it's secondary the available short circuit current is;

$$\begin{aligned} I_{sc} &= P_{sc} / V_{SEC} \\ &= 66700 / 120 \\ &= 556A \end{aligned}$$



In this example any protective device in the control circuitry powered directly by the control transformer must be able to interrupt at least 556A.

Since there is generally some tolerance in impedance ratings it is often assumed this value can vary by up to 10%. Factoring this into the above calculations would increase the available short circuit current to 618A.

With regards to the SIGNEXT® - CBM modules, the interrupting current ratings are as follows:

SIGNEXT® - CBM/1:	1000A
SIGNEXT® - CBM/8:	1000A
SIGNEXT® - CBM/8/35mm:	500A

In the example above the CBM/1 and /8 modules would be suitable while the CBM/8/35mm would not be.

DC CIRCUITS

When the control transformer provides power to an AC/DC power supply which then supplies DC power to protective devices the maximum fault current available from the power supply should be known but very few power supply manufacturers provide this information. This is because the power supply has internal circuitry that turns off the unit if the output is short circuited so in theory no protective devices are needed in the DC circuits. In practice protective devices are often used. For example, a 10A power supply often powers multiple 1A fuses or circuit breakers. This might be done to allow smaller gauge wires (rated less than 10A) to be used or simply to isolate a single circuit. Users assume that a short circuit will cause the protective device to act while the power supply continues to operate.

The manufacturer should provide the maximum current the power supply can deliver into a short circuit and the duration. The latter is very important – when short circuited the power supply's own protection circuitry will turn off the output but only after some period of time. Can the protective device interrupt the power supply's short circuit current? Will the short circuit damage anything within the period of time between the short occurring and the power supply turning off?

The SIGNEXT® - CBM module interrupting current ratings shown above apply for 24Vdc applications as well as 120Vac applications. Will they operate before a power supply in a short circuit condition shuts down? The user will need to know the power supply's short circuit current rating, including the duration, and compare this to the trip curves published for the SIGNEXT® - CBM modules.

For a more detailed discussion of DC power supplies and protective devices please see the white paper **What Does "Power Boost" Mean With Regards To DC Power Supplies?**