

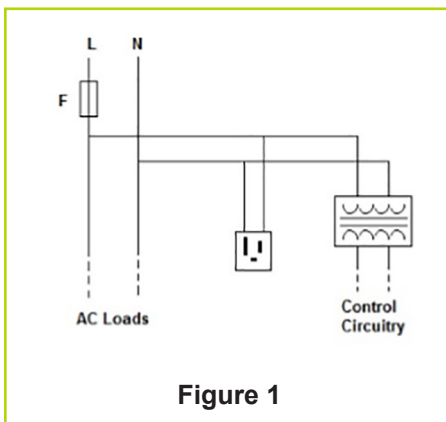

AC Outlets and the Interrupting Capacity of Control Cabinets

Control cabinets have an overall interrupting capacity rating. The rating refers to the maximum fault current that can be interrupted safely. The overall ratings can be impacted by AC maintenance outlets even though the outlet does not power the load or loads controlled by the cabinet and are only used intermittently such as during commissioning or maintenance.



In figure 1 the interrupting capacity of the cabinet would be equal to the interrupting rating of the fuse F. The control transformer limits the short circuit current available in the control circuitry. Since the AC outlet is connected directly to F the rating of the fuse cannot exceed 15A if a standard outlet is used. If the interrupting rating of F is 10KA then the overall rating of the cabinet is 10KA.

However, in many cases the current available from the AC outlet is limited to 5A. This is to prevent the outlet from being used for power tools. If the total current requirement does not exceed 5A then F can be a 5A fuse and the interrupting rating of the fuse determines the overall interrupting capacity of the cabinet. If the total current requirement is greater than 5A then a fuse or circuit breaker has to be added for the outlet.

In figure 2 the AC outlet has its own fuse. In this situation F2 could be rated 5A while F1 is rated for the total current requirement. The overall interrupting capacity of the cabinet will equal the lowest interrupting current rating of F1 and F2. If F1 is a CC fuse rated 200KA interrupting while F2 is a 5x20mm fuse rated 1000A interrupting then the overall rating of the cabinet is just 1000A. Changing F2 to a T-class fuse or a CC fuse would increase the overall cabinet rating considerably. Another issue if F2 is a 5x20mm fuse is that these fuses provide supplemental protection, not branch protection. The T-class or CC fuse would be much better options as they are branch rated devices.

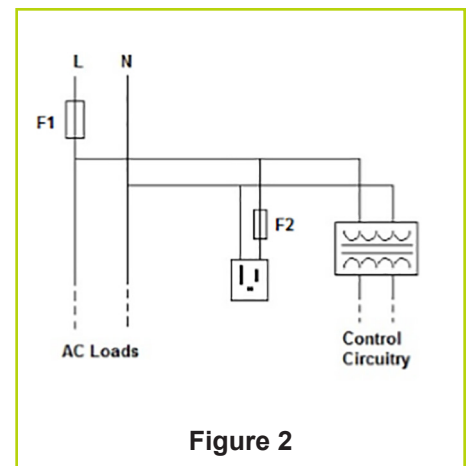

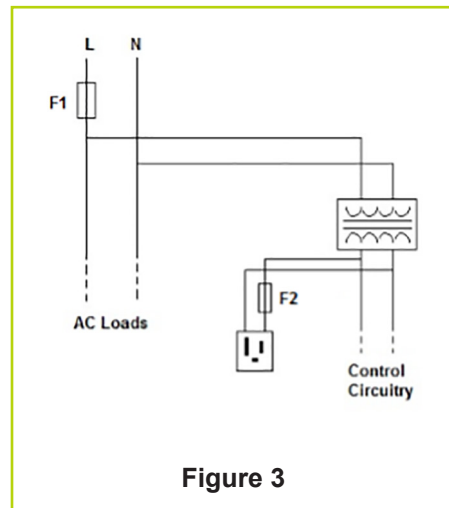

Figure 3

F2 could be replaced by a circuit breaker but the situation does not change with regards to the overall interrupting rating of the cabinet.

Another option would be to power the AC outlet from the control transformer if the latter has the capacity. Referring to figure 3, as long as F2 has an interrupting rating greater than the short circuit current rating of the control transformer then it can be a supplemental device such as a 5x20mm fuse or a supplemental circuit breaker and not impact the overall cabinet interrupting capacity rating.

Emphatec's VANGUARD® family of AC outlet modules includes a basic duplex, single outlets with supplemental fuse or circuit breaker and a single outlet with a branch rated fuse. Regardless of the configuration shown in the above illustrations Emphatec has a solution.